

(No Model.)

2 Sheets—Sheet 1.

G. T. REISS.
TURRET LATHE.

No. 406,003.

Patented June 25, 1889.

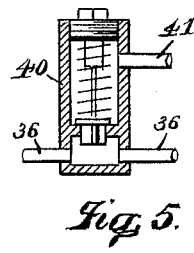
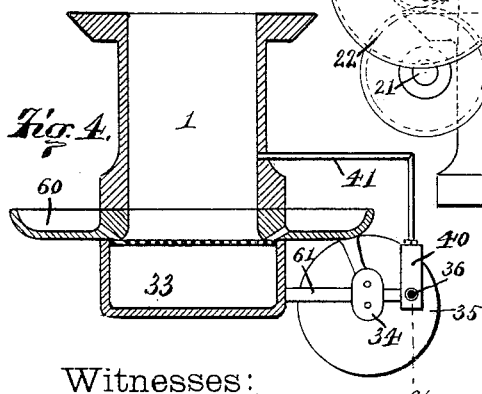
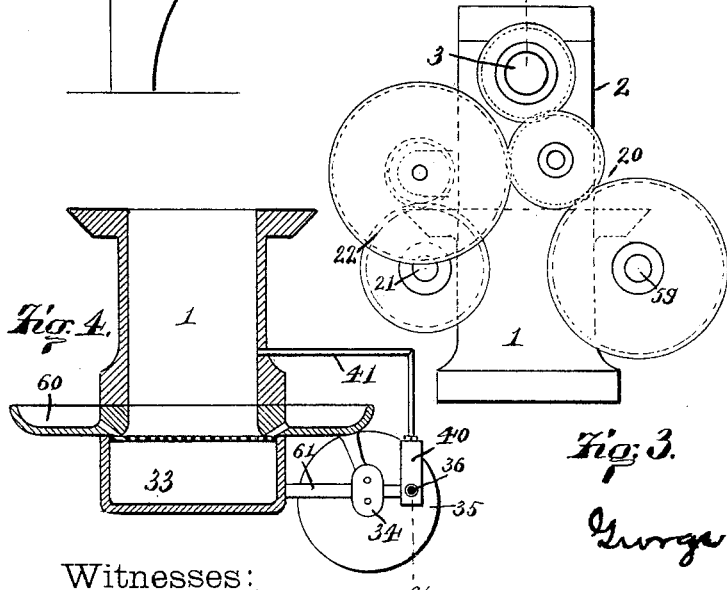
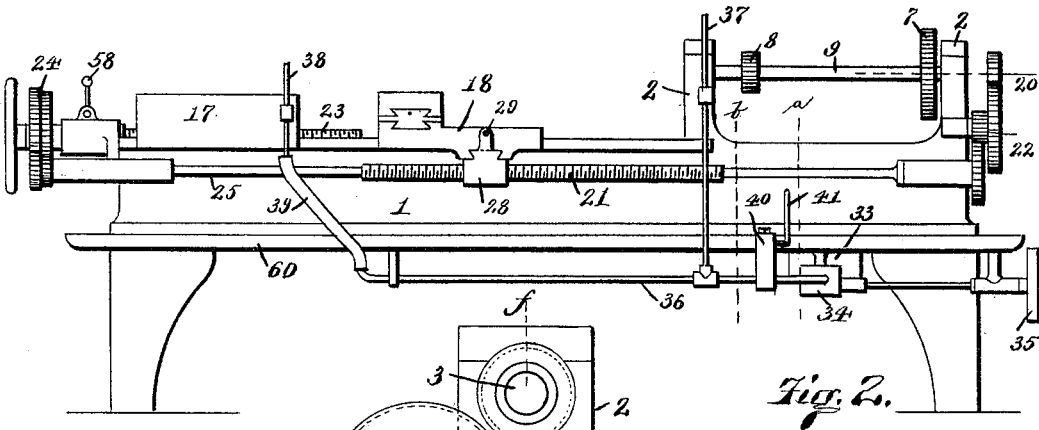
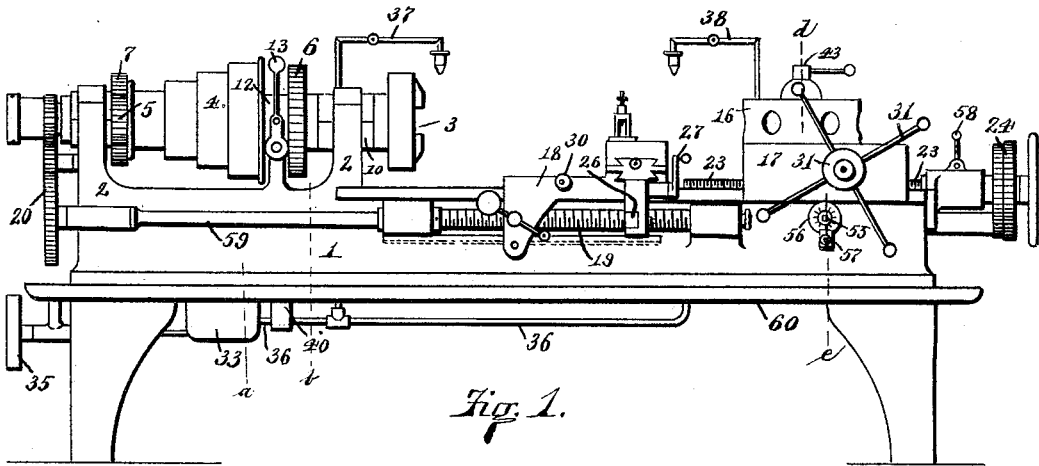

Witnesses:
Waldward
R S Carr

George T. Reiss
Inventor
by James W. See
Attorney

(No Model.)

2 Sheets—Sheet 2.

G. T. REISS.
TURRET LATHE.

No. 406,003.

Patented June 25, 1889.

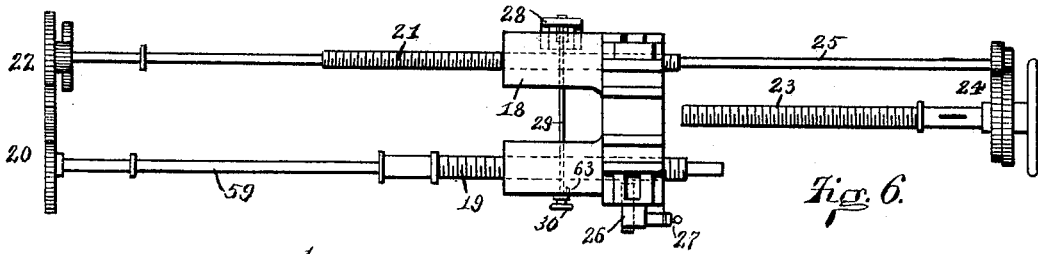

Fig. 6.

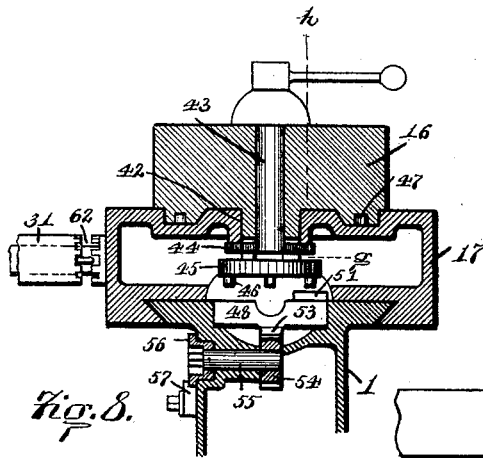

Fig. 8.

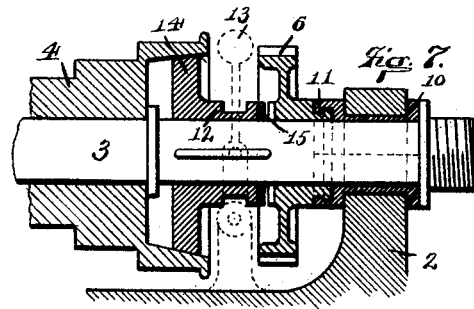

Fig. 7.

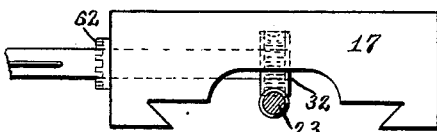

Fig. 9.

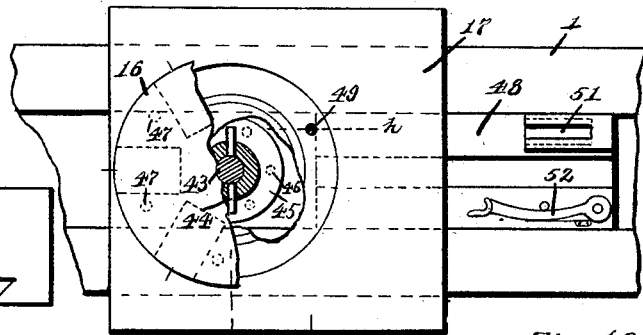

Fig. 10.

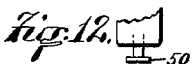

Fig. 12.

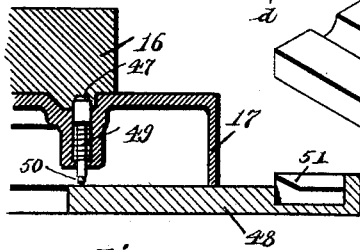

Fig. 11.

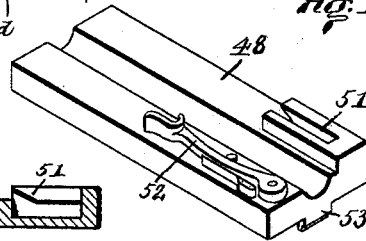

Fig. 13.

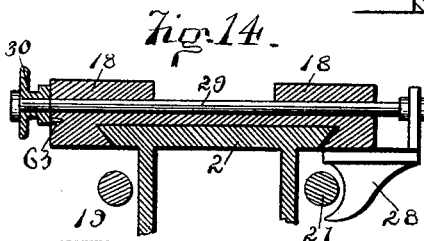

Fig. 14.

Witnesses:
W. Woodward
P. S. Carr

George T. Reiss
Inventor
by James W. See
Attorney

UNITED STATES PATENT OFFICE.

GEORGE T. REISS, OF HAMILTON, OHIO, ASSIGNOR TO THE NILES TOOL WORKS, OF SAME PLACE.

TURRET-LATHE.

SPECIFICATION forming part of Letters Patent No. 406,003, dated June 25, 1889.

Application filed February 2, 1889. Serial No. 298,440. (No model.)

To all whom it may concern:

Be it known that I, GEORGE T. REISS, of Hamilton, Butler county, Ohio, have invented certain new and useful Improvements in Turret-Lathes, of which the following is a specification.

This invention, some features of which are applicable to lathes generally, has been devised with special reference to turret-lathes, and the improvements will be readily understood from the following description, taken in connection with the accompanying drawings, in which—

Figure 1 is a front elevation of a turret-lathe embodying my improvements; Fig. 2, a rear elevation of the same with various details omitted; Fig. 3, an end elevation of the same at the left hand of Fig. 1, showing the arrangement of gearing; Fig. 4 a vertical transverse section through the bed of the lathe and through the oil-discharge pipe, the plane of this section being indicated by line *a* of Fig. 1; Fig. 5, a vertical section of the safety-valve in plane of line *c* of Fig. 4; Fig. 6, a plan of the carriage and general feed-work; Fig. 7, a vertical section of part of the driving-cone and certain accessories in plane of line *f* of Fig. 3; Fig. 8, a vertical transverse section of bed, turret, and turret-slide in planes of lines *d* and *e* of Fig. 1, the pawl-block appearing in this section with the pawl omitted; Fig. 9, a rear elevation of the turret-slide shaft and turret feed-screw in vertical transverse section; Fig. 10, a plan of part of the bed, showing the turret with part broken away, the turret-slide with an aperture broken through it and exposing a portion of the pawl-block to the rear of the turret-slide; Fig. 11, a vertical section, in plane of line *h* of Figs. 8 and 10, of a portion of the turret-slide and the pawl-block, showing the pawl and pawl-drawing devices; Fig. 12, a rear elevation of the foot of the dowel-pin; Fig. 13, a perspective view of the pawl-block, and Fig. 14 a vertical transverse section through the bed and carriage at the center of rod 29 of Fig. 6.

Some features of my improvement have to do with the lubrication of the cutting-tools, such lubrication being effected by a supply of oil or water or other suitable lubricating material. In this specification, in referring to

these features, when I use the word "oil" I intend that word as comprehending any suitable liquid lubricant.

March 6, 1883, United States Letters Patent No. 273,313 were granted to the Niles Tool Works, of Hamilton, Ohio, on my application for improvements in metal-screw machines. I may refer to that patent in the present specification, and in doing so will refer to it as the "Niles patent."

In the accompanying drawings, 1 indicates the bed of the lathe; 2, the head-stock; 3, the lathe-spindle, to be, preferably, hollow; 4, the driving-cone loose on the spindle; 5, the cone-pinion fast on the cone to serve in driving the back gear; 6, the face-gear, loose on the spindle, to serve in driving the spindle through the intermediacy of the back gear; 7, the back gear-wheel, always gearing with the cone-pinion; 8, the back gear-pinion, always gearing with the face-gear; 9, the back gear-shaft, on which gears 7 and 8 are fixed; 10, the front spindle-box of the head-stock, this box being, as usual, in lower and upper halves; 11, Fig. 7, a collar on the forward hub of the face-gear engaging within the collar-groove in the rear end of the front spindle-box, whereby the face-gear is prevented from endwise motion by the box; 12, a sliding hub splined to the spindle between the driving-cone and the face-gear; 13, a hand-lever for sliding this hub to the right or the left; 14, a friction-disk on this sliding hub engaging a corresponding frictional surface on the cone and adapted, when the hub is moved toward the cone, to lock the spindle to the cone, and thereby give the spindle the same rotation as the cone; 15, clutch-teeth upon the contiguous faces of face-gear and sliding hub, these teeth being adapted to intermember when the sliding hub is moved to the left, and thereby lock the spindle to the face-gear and cause the spindle to revolve at the speed of the face-gear; 16, the turret; 17, the turret-slide supporting the turret which revolves upon it, and capable itself of longitudinal movement on the bed of the lathe; 18, the lathe-carriage; 19, the lead-screw, properly mounted upon the front side of the bed and arranged for removal and replacement in the manner, for instance, as set forth in the Niles patent, the intention be-

ing that this lead-screw shall be employed only for screw-cutting, and that a different lead-screw shall be inserted in place when a change of pitch is wanted; 20, gearing through which the lathe-spindle rotates the lead-screw; 21, the feed-screw, mounted upon the back of the lathe-bed, the intention being that this screw shall be used for the regular feeding of the carriage; 22, gearing through which the lathe-spindle imparts rotary motion to this feed-screw; 23, the turret-screw, centrally disposed at the tail end of the lathe-bed at about the level of the top of the bed, this screw serving in feeding the turret along the lathe-bed, and also serving as a rack when the turret is to be quickly traversed by hand, as in the Niles patent; 24, gearing by which rotary motion is imparted from the feed-screw to the turret-screw, this gearing being illustrated as of the cone type, as in the Niles patent, so as to provide two rates of feed for the turret; 25, an unthreaded extension of the feed-screw from the feed-screw proper toward and beyond the tail end of the lathe to permit connection with the gearing 24; 26, an open-and-shut nut at the front of the carriage to engage the lead-screw; 27, the hand-lever for opening and shutting this nut, and for simultaneously moving the tool-head, as in the Niles patent; 28, an open-and-shut nut sliding horizontally on the back of the carriage, engaging the feed-screw; 29, a rod attached to and reaching forward from this nut to the front of the carriage; 30, a handle on the front end of this rod, by which the rod may be moved endwise in opening and shutting the nut; 31, the clutch-capstan on the turret-slide to serve in moving the turret rapidly along the lathe-bed by hand, and to serve also in locking the turret-pinion when the movement is to be effected by power; 32, the turret-pinion fast on the shaft of the clutch-capstan and engaging with its teeth the turret-screw, the pinion thus serving as a pinion engaging the turret-screw and as a rack when the turret is to be moved by hand, and serving also when locked by the clutch-capstan as a nut for the turret-screw when the turret is fed through the medium of this screw, as in the Niles patent; 33, the usual oil-reservoir placed beneath the lathe-bed and arranged to receive the oil employed in lubricating the cutting, the oil draining down through the hollow lathe-bed, as usual; 34, a pump of ordinary rotary-pump construction arranged to draw its supply from the oil-reservoir and to force the same through suitable conduits to drip-cocks over the cutting-tools; 35, the pump-pulley, by means of which this pump may be continuously driven by belt from any suitable driving-shaft, which driving-shaft may, if desired, be the usual countershaft through which the lathe is driven; 36, the oil-discharge pipe leading from the pump; 37, a branch pipe leading from this discharge-pipe to a drip-cock which may be disposed over the work near the chuck; 38, a branch pipe

leading from the discharge-pipe and attached to the turret-slide and adapted to travel with it and provided with a drip-cock which may be disposed over the operating turret-tool; 39, a flexible pipe or hose connecting this branch pipe with the oil-discharge pipe, whereby communication is maintained through it and the traveling movement of the turret-slide; 40, a safety-valve connected with the oil-discharge pipe between the pump and either of the branch pipes, this safety-valve being an ordinary loaded valve arranged to discharge when there is an excess of pressure under the valve; 41, a relief-pipe communicating with the safety-valve above this valve, and with the interior of the lathe-bed; 42, the pivot-hole in the top of the turret-slide, in which fits and through which projects downwardly the central pivot-hub of the turret; 43, the turret-bolt centrally disposed in the turret and having the usual clamp-nut at its upper end; 44, a T-head on the lower end of the turret-bolt, the ears of this head projecting freely sidewise through mortises in the downwardly-projecting turret-hub, the upper surface of the ears engaging below the hub containing the pivot-hole 42, whereby an upper strain upon the turret-bolt causes the ears to impinge against that hub, and thus clamp the turret tightly between the turret-slide and the clamp on the turret-bolt; 45, a disk secured to the lower end of the turret-hub, which projects through the pivot-hole in the turret-slide, this disk being disposed within the turret-slide; 46, ratchet-pins, one for each tool-hole in the turret, projecting downwardly from the disk; 47, a circular series of dowel-holes—one for each tool-hole in the turret—these dowel-holes being in the under surface of the turret; 48, a pawl-block fitted in a central groove in the upper surface of the lathe-bed along the portion thereof on which the turret moves, this block carrying the mechanism for drawing the dowel and for rotating the turret, the block appearing in Fig. 8 with the turret-rotating pawl removed; 49, the turret-dowel, a pin fitted for vertical sliding motion in the turret-slide and adapted to have its upper end engage with any one of the dowel-holes in the turret, the dowel being pressed normally upward by a spring; 50, a T-head on the lower end of the dowel; 51, a pair of inclines fast upon the pawl-block and so presenting themselves that when the turret-slide is moved backward the T-head of the pawl will engage these inclines and be by them drawn downwardly, thus withdrawing the dowel from the dowel-hole in the turret with which it may at the time be engaged, a reverse motion of the turret-slide removing the T-head from the influence of the inclines and permitting the dowel to again move upward into engagement with any dowel-hole which may then present itself; 52, a pawl carried by the pawl-block and having a forward end adapted to engage the ratchet-pins 46, and so presenting itself that when the turret-slide

is moved rearwardly a proper distance one of these ratchet-pins will be engaged by the pawl, and, as the backward motion of the turret continues, the turret be forced into partial rotation; 53, a rack formed or secured upon the lower surface of the pawl-block; 54, a pinion engaging this rack; 55, the shaft to which this pinion is secured, this shaft being journaled in the lathe-bed and presenting at the front thereof an outer end adapted to receive a wrench or handle, by means of which the shaft may be turned; 56, a disk secured to this shaft outside the lathe-bed and having upon its face a series of radial graduations; 57, a clamp secured to the lathe-bed and engaging the graduated disk and bearing an index-mark, and serving as a means for clamping the disk against rotation, and also serving as an index for the graduations of the disks; 58, a hand-lever for shifting the clutch of the cone-gearing 24, as in the Niles patent; 59, the lead-screw shaft reaching from the gearing 20 to the lead-screw, and forming what may be called the "prominent" part of the lead-screw, the various lead-screws being connected and disconnected from this shaft, as desired, as in the Niles patent; 60, the usual oil-tray around the base of the lathe-bed, by which the general oil-drippings are caught and drained to the oil-reservoir; 61, the oil-supply pipe through which the oil-pump receives oil from the oil-reservoir; 62, the clutch of the clutch-capstan, one member of this clutch being on the capstan-hub, which is splined on the shaft of pinion 32 and the other member of which is fast on the turret-slide, whereby the pinion 32 may be locked against rotation; and 63, a pin in the handle 30, loosely engaging a hole in the lathe-carriage, this pin serving when the handle is pulled forward to partially rotate and prevent the retreat of the handle.

The cone 4 revolves by belt-power, as usual, at comparatively high speed, the back gear revolving continuously at comparatively lower speed. Consequently the face gear 6 is continuously revolving in the same direction with the cone, but at a much lower rate of speed. By throwing lever 13 to the right the spindle becomes suddenly locked to the face-gear and revolves at slow speed with it. By leaving the lever in the neutral position the spindle remains stationary. By throwing the lever to the left the spindle becomes locked to the cone through the medium of the friction disk and the spindle revolves at the high speed of the cone, and the nature of the friction-engaging device is such that the high rate of speed imparted to the spindle is installed gradually instead of with a sudden shock, which would be the case were the spindle locked to the cone through the medium of a toothed clutch. Owing to the comparatively low rate of speed of the face-gear, the toothed clutch may be employed without damaging shock. The collar engagement 11 gives a fixed endwise position to the face-

gear and frees the spindle from endwise strains as the toothed clutch is thrown in or out.

The operation of the feeds is as follows: A piece of work revolved by the spindle is operated upon by the carriage-tools, the feed being produced by the feed-screw 21, to which the carriage is locked by the open-and-shut nut 28. When the turret-tool is to be brought into operation, the nut 28 is disengaged, the turret moved by hand to initial position of feed, as usual, and the capstan-clutch locked so that the pinion 32 becomes a fixed nut upon the turret-slide, whereupon the turret-slide becomes fed toward the spindle by means of the turret-screw 23. To retract the turret by hand, the capstan-clutch is disengaged, whereupon the pinion 32 becomes practically a pinion engaging the screw 23, which then becomes a rack whether said screw be revolving or stationary. For chasing operations upon the work with the carriage-tools the open-and-shut nut 26 is engaged with the lead-screw. The oil-pump forces oil through the drip-cocks upon the branch oil-pipes, which cocks are adjusted, as usual, over the operating-tools and the surplus oil falls to the bed and oil-tray and drains thence to the oil-reservoir, whence the pump continuously draws it and forces it again to the branch pipes and drip-cocks, the continuously-running pump serving to maintain a constant supply of oil at the drip-cocks. The oil may be caused to flow alternately or simultaneously from the two drip-cocks, or in case one only is needed the other may be closed, or, when desired, both may be closed. In the latter case the pump still continues to draw its oil from the oil-reservoir and to force it to the oil branch pipes, where it finds no outlet. This produces an excessive pressure of oil between the pump and the drip-cocks, and this excess of pressure causes the safety-valve to lift and the discharge to take place into the bed through pipe 41, whence the oil finds its way again to the oil-reservoir.

Normally the turret-dowel engages a hole in the turret. By moving the turret back by hand the T-shaped foot of the dowel runs under the inclines 51 and the dowel is withdrawn, whereupon the turret may be revolved by hand to bring any desired turret-tool in line with the spindle, after which the turret may be advanced by hand or power to cause the turret-tool to operate upon the work. If, however, after the turret has been moved back to such position that the dowel will be withdrawn, the backward movement be still continued, one of the ratchet-pins 46 will come in contact with the pawl 52, and the backward motion of the turret being still continued the turret will be partially rotated, so as to bring the succeeding turret-tool in line with the spindle, and upon the turret being moved forward the dowel-pin will engage a new dowel-hole and dowel the turret in the new position. Thus, by moving the turret back and

forth a proper distance successive partial rotations may be given to the turret to bring the desired turret-tool into working position successively or otherwise, as desired.

5 Normally, when not clamped, the turret is free to revolve in the turret-slide when turned by hand or by the pawl. When the turret is in a desired position, the turret may be clamped to the turret-slide against rotation,
10 the T-head 44 impinging against the foot of the hub on which the turret revolves.

Were the dowel-drawing inclines and the pawl in a fixed position upon the lathe-bed, it would be necessary in order to utilize them to
15 move the turret clear back to their position each time the turret was to be rotated by them, and with a long lathe-bed and with a short piece of work in hand a long rearward trip of the turret would be involved at each
20 use of the inclines and pawls. To avoid this the pawl-block 48 is to be adjusted along the lathe-bed into such position as is suited for the length of work in hand, whereby the turret need be moved backward only such a distance
25 as is called for by the length of work in hand. The pawl-block is adjusted by rotating the pinion-shaft 55, and when the pawl-block has been adjusted into desired position it is fixed in such position by means of
30 the clamp 57, which bites upon the disk 56 and prevents accidental rotation of the pinion. The graduations on the disk serve in indexing the position of the pawl-block along the bed, and for this purpose the disk may be
35 graduated arbitrarily or it may be graduated to indicate inches of travel of pawl-block.

I claim as my invention—

1. The combination, substantially as set forth, of a spindle, a cone-pulley free to revolve thereon and having a frictional clutch-surface, a pinion fast on the cone-pulley, a face-gear free to revolve on the spindle and having a toothed clutch, a back gear engaging said pinion and face-gear, and a sliding hub
40 splined to the spindle between the cone-pulley and face-gear and provided with a frictional clutch-surface to engage the frictional clutch-surface of the cone-pulley and with a toothed clutch to engage the toothed clutch
45 of the face-gear.

2. The combination, substantially as set forth, of a spindle, a cone-pulley loose thereon, a pinion fast on the cone-pulley, a back gear, a box for the spindle provided with a collar-groove, a face-gear loose on the spindle between the cone-pulley and box and having a hub-collar engaging said collar-groove, and a sliding hub splined to the spindle between the cone-pulley and face-gear and provided
50 with clutches for engagement with suitable clutches on the cone-pulley and face-gear.

3. In a lathe, the combination, substantially

as set forth, of a lead-screw mounted at one side of the lathe-bed and geared to the lathe-spindle, an open-and-shut nut on the lathe-carriage and adapted to engage the lead-screw,
65 a feed-screw mounted on the opposite side of the lathe-bed and geared to the lathe-spindle, an open-and-shut nut on the lathe-carriage adapted to engage the feed-screw, turret-screw mounted at the tail end of the lathe-bed and geared to the feed-screw, and a turret-slide engaging the turret-screw.
70

4. In a lathe, the combination, substantially as set forth, of a feed-screw mounted at the back of the lathe, an open-and-shut nut on the lathe-carriage, arranged to slide horizontally and adapted to engage such screw, a sliding rod connected with such nut and reaching across the lathe bed and carriage to the front of the carriage, and a handle on said rod at the front of the carriage.
75

5. In a turret-lathe, the combination, substantially as set forth, of a turret-slide having a downwardly-projecting hub with a pivot-hole for the turret, a turret having a hub fitting and projecting downwardly through said pivot-hole and below said first-mentioned hub and mortised horizontally at such projection, a ratchet-disk secured to the lower end of said turret-hub below said mortise, a turret clamping-bolt axially disposed in the turret and its hub, and a T-head on the lower end of said bolt with its ears projecting through said mortise and engaging the downwardly-presenting
80 surface of said first-mentioned hub.
85

6. In a turret-lathe, the combination, substantially as set forth, of a turret-slide, a turret mounted thereon and having ratchet-teeth, a dowel in the turret-slide, adapted to engage
90 dowel-holes in the turret, a pawl to engage said ratchet-teeth, inclines to engage said dowel, and a pawl-block carrying said pawl and inclines and fitted for longitudinal adjustment along the lathe-bed, and devices for
95 adjusting and securing said pawl-block.

7. In a turret-lathe, the combination, substantially as set forth, of a turret-dowel having a T-shaped foot and inclines attached to the lathe-bed and adapted to be engaged by
100 said foot.
105

8. In a turret-lathe, the combination, substantially as set forth, of a pawl-block arranged to be adjusted along the lathe-bed and provided with a rack, a pinion-shaft journaled
110 in the lathe-bed and fitted with a head for turning it, a pinion thereon engaging said rack, a graduated disk on said shaft, and a clamp engaging said disk.

GEO. T. REISS.

Witnesses:

J. W. SEE,

W. A. SEWARD.